

## Door Operator for Automatic Sliding Door System Design

WIN MOET MOET HTWE<sup>1</sup>, MYO THET TUN<sup>2</sup>

<sup>1</sup>Dept of Electrical Power Engineering, Mandalay Technological University, Mandalay, Myanmar,  
E-mail: win.isotope@gmail.com.

<sup>2</sup>Dept of Electrical Power Engineering, Mandalay Technological University, Mandalay, Myanmar,  
E-mail: myohtettun7@gmail.com.

**Abstract:** Over the years, several automatic systems have been employed in the world. This journal shows the design of the automatic sliding door operator and power supply for module circuit. Automatic sliding door operator performs for opening or closing the door automatically. Automatic door is an automated movable barrier installed in the entry of a room or building to restrict access, provide ease of opening a door or provide visual privacy. Automatic doors are specially designed to reduce congestion and increase access and can make the door use easier. Sensors are detected when people approach the doors and trigger them to slide open. When someone enters in front of the sensors inside or outside the room, control module in door operator receives the signal and controls through the motor which drives the door sliding. The system can be used on supermarkets exhibition or added to any door to facilitate unassisted entry or exist from homes, offices, etc.

**Keywords:** PIC 16F887 microcontroller, DC motor, H-bridge (L298), Sensors, Sliding Door.

### I. INTRODUCTION

Nowadays, population is more increasing in megacities all over the world because of large density population, public areas. These places have many difficulties to use the manual doors. The manual doors are often convenient because they are too hard to push open, especially with full hands or while pushing a stroller. Therefore the face the problems of scare to install the doors to be save and easier more convenience access than manual doors. And then by using the door sliding system, it can reduce the human labour and wages time to spend door in and out because of converted from manual system to automatic system. Automatic sliding doors have flat panels that slide horizontally and linearly, with a variety of configurations. The automatic door sliding system consists of sensing system, main controller circuit and motor. Today, the field of microcontrollers is in the beginnings of the development of integrated-circuit technology. Microcontrollers are the most widespread, varied, flexible electronic control devices. The number of applications is vast and increasing daily. This approach is to modulate a design that uses a popular PIC 16F887 microcontroller to control the DC motor for automatic sliding door. There are three main facts to control a motor, speed, direction, and position. The commonly electrical motor used in motion control system. Sometimes the direction of rotation needs to be changed. H-bridge circuit (L298) can be used.

### II. AUTOMATIC DOOR SLIDING OPERATOR

The operator performs automatically to open the door, and then closes. The automatic sliding door operator is mounted above the door.

Fig 1 shows the sliding door operator with components. These components are;

1. End Stop (edge detector)
2. Motor
3. Controller
4. Power supply (adaptor)
5. Belt
6. Wheel (motor wheel and pulley)
7. Battery

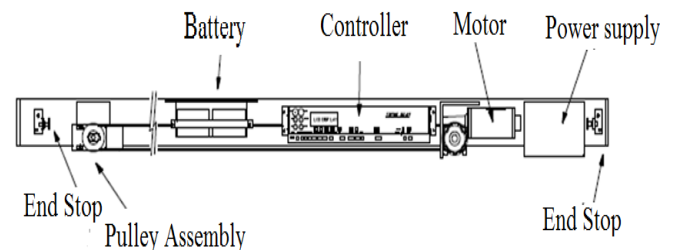

**Fig1. Schematic Diagram of Automatic Sliding Door Operator**

In operator, a belt is a flexible power transmission element that fits securely on a set of pulleys or sheaves. When the belt is used for speed reduction, the smaller sheave is mounted on the high speed shaft, like the shaft of an electric motor. The door panels are mounded on the belt. So, the belt moved with the motor running to open or close the door. Battery backup system provides a constant variable charge when the door is not operation depending on the condition of the batteries. The Batteries are constantly monitored to on firm that they have

enough power in them to carry out their emergency power failure procedure. A monitored back-up system should be provided for use in case of mains power interruption. The push buttons are used for end stop. The button is mounted at the end of the operator to stop the door opening or closing.

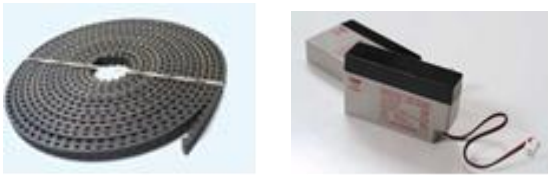

(a) (b)

**Fig2. Other accessories of sliding door operator (a) Belt and (b) Batteries.**

**II. MOTOR USED IN SLIDING DOOR SYSTEM**

The commonly electrical motor used in motion control system includes the DC motor, DC brushless motor, stepping motor and AC motor. One of the most attractive feature of DC motors in comparison with AC motors is the ease with which there can be varied. It can be combined with control electronic gearboxes and encoders in modular system to provide a flexible adaptable, market-oriented solution. Basically, five different types of DC motors are used in industrial applications: separately excited DC motor, series wound, shunt wound, compound wound, and permanent magnet. Several factors must be considered when selecting a DC motor for a specific application. First, decide what the allowable variation in speed and torque can be for a given change in load. Each type of motor has benefits that are advantageous for certain applications. The DC motor and drive specifications should always be consulted to determine the specific speed and torque capabilities of the system. For sliding door system, permanent magnet motor is the best choice.

Permanent magnet DC motor converts electrical energy into mechanical energy through the interaction of two magnetic fields. One field is produced by permanent magnet assembly; the other field is produced by an electrical current flowing in the motor windings. These two field result in a torque which term to rotate the rotor. As the rotor turns, the current in the winding is commutated to produce continuous torque output. The stationary electromagnetic field of the motor can also be wire wound like the armature (called a wound field motor) or can be makeup of permanent magnet. Permanent magnet motors are probably the most commonly used DC motors but these are also some other type of the DC motor. DC motor operates from a direct current power source. This action is called commutation. Very many DC motors (brush type) have built in commutation meaning that as the motor rotates mechanical brushes automatically commutate coils on the rotor. DC brush motor can be used in a variety of products such as toys, servo mechanisms, value actuators, robots and automotive electronics.

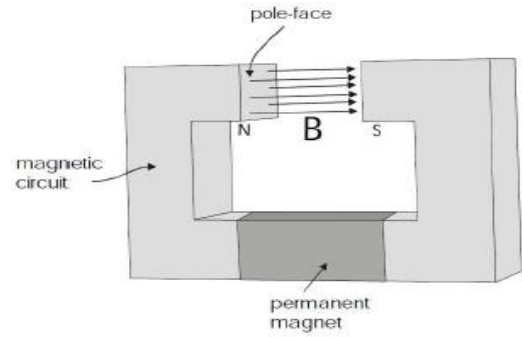

**Fig3. Production of magnetic field by permanent magnet**



**Fig 4. Cross section of the PMDC motor**

There are several typical advantages of a PM motor when compared to AC or wound field DC motor, PM motor are usually smaller in overall size and lighter for a given power rating. Furthermore, since the motor field created by the permanent magnet is constant, the relation between torque and speed is very linear. A permanent magnet motor can provide relatively high torque at low speeds and the PM electric field provides some inherent self-braking when power to the motor is shunt off. In a DC motor the field B is usually produced by means of a strong permanent magnet. The flux is 'guided' by means of a steel magnetic circuit to two pole faces as shown in Fig 3. This part of motor is known as the stator. Fig 4 shows the cross section al area of the motor.

**III. POWER SUPPLY SYSTEM**

In this power supply and control circuit, the following components are comprised and they perform the power conversion and control for automatic sliding door system.

1. Transformer
2. Rectifier
3. Regulator

**A. Transformer**

Important design specifications of transformer are given below:

E.M.F equation,  
 $E_1 = 4.44 f T_1 B_m A_i$  volts (1)  
 $E_2 = 4.44 f T_2 B_m A_i$  volts (2)

The e.m.f per turn,  
 $E_t = 4.44 f B_m A_i$  (3)

Where,  $E_1$  = induced e.m.f in primary winding  
 $E_2$  = induced e.m.f in secondary winding  
 $f$  = frequency of supply  
 $A_i$  = net cross-sectional area of the core

## Door Operator for Automatic Sliding Door System Design

$B_m$  = maximum value of main flux  
 $T_1$  = number of turns in the primary winding  
 $T_2$  = number of turns in the secondary winding

E.M.F per turn equation,  $E_t = k (KVA/phase)$  (4)

A suitable value of the factor,  $k$  can be taken depending upon the type of transformer.

For single phase transformers,

$$Q = 2.22 f B_m \delta K_w A_w A_i \times 10^{-3} \text{ kVA} \quad (5)$$

Where,  $Q$  = output of single phase transformer (kVA)  
 $\delta$  = average value of current density ( $A/m^2$ )  
 $A_w$  = window area ( $m^2$ )  
 $K_w$  = window space factor

### B. Rectifier

The full wave bridge rectifier in Fig 5, is composed of four diodes in a diamond shape. The transformer secondary is connected to two corners of the diamond, and the load is connected to the remaining corners. When the top of the secondary winding is positive, diodes  $D_2$  and  $D_4$  are forward-biased; current flows through diode  $D_2$ , then through the load, and through diode  $D_4$ . The remaining two diodes are OFF.

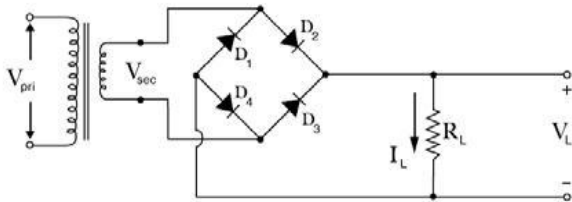
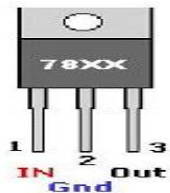

**Fig 5. Full-wave bridge rectifier**

When the bottom of the winding is positive, diodes  $D_3$  and  $D_1$  are now forward-biased and turn ON; similarly, diodes  $D_2$  and  $D_4$  are now OFF. Thus, the full voltage between both ends of the transformer secondary winding is utilized and current flows during both halves of the input cycle. The full-wave bridge rectifier makes the most efficient use of the transformer, when compared to the half-wave and the full-wave rectifiers [10].

### C. Regulator

The regulator can be chosen for operation of controller and other peripheral devices. There are many type of IC regulators, among them, LM 78xx series is shown in Fig 6, are chosen. The LM 7824 regulator can be used for motor, LM 7812 regulator for alarm unit and LM 7805 regulator for operation of PIC microcontroller and other peripheral devices.



**Fig 6. 78xx Series Regulator**

## IV. DESIGN OF POWER SUPPLY CIRCUIT

A power supply can be built with 220VAC/50Hz/24VDC transformer. In Fig 7, it connected to the AC supply line to step down the AC voltage to get desired amplitude, and then rectifying that AC voltage, filtering with a capacitor and RC filter.

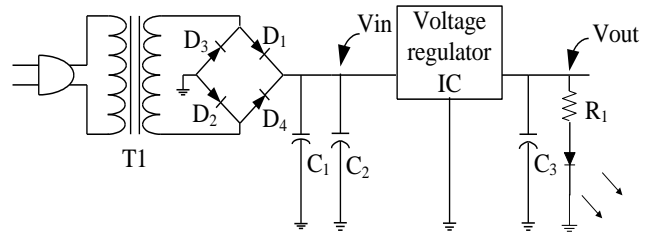

**Figure7. Power Supply Circuit Diagram**

Consideration for Full-wave Bridge Rectifier Circuit,

$$V_{s(max)} = V_{o(max)} + 2 V_r \quad (6)$$

$$V_{s(rms)} = \frac{V_{s(max)}}{\sqrt{2}} \quad (7)$$

Where,

$V_{o(max)}$  = Desired output voltage, V

$V_{s(rms)}$  = The secondary voltage of the step-down transformer, V

$V_{s(max)}$  = The peak value of  $V_s$ , V

$V_r$  = Diode cut-in voltage ( Si for 0.3 V, Ge for 0.7)

Consideration of Voltage Regulator Circuit,

The value of  $C_1$ ,

$$C_1 = \frac{10^4 I_{DC}}{0.48 V_{DC}} \quad (8)$$

The working voltage of  $C_1$ ,

$$WV_{C1} > 1.7 V_{DC} \quad (9)$$

Where,

$I_{DC}$  = desired output current

$V_{DC}$  = desired output voltage

**Table1: Value for Rectifier and regulator From Calculation**

Regulator	LM 7824	LM 7812	LM 7805
$V_0$ or $I_{DC}$ (V)	24	12	5
$I_0$ or $I_{DC}$ (A)	0.5	0.5	0.5
$V_r$ (V)	0.7	0.7	0.7
$V_{s(max)}$ (V)	25.4	13.4	6.4
$V_{s(rms)}$ (V)	17.96	9.475	4.525
Calculate, $C_1$ ( $\mu F$ )	434.028	868.06	2083.33
Selected, $C_1$ ( $\mu F$ )	500	1000	2200
$WV_{C1}$ (V)	40.8	20.4	8.5

The Required Parameter for Circuit, the secondary winding current,

$$I_{AC} = 1.6 I_{DC} = 0.8A \quad (10)$$

To reduce amount of ripple of DC output voltage, a capacitor filter is used. A standard 0.001 F and 470µF capacitor is above the output voltage a good starting point. C<sub>2</sub> and C<sub>3</sub> are chosen respectively 0.001F and 470µF capacitor.

To choose the bridge diodes, they are rated by average forward current (I<sub>FAV</sub>) and peak inverse voltage (PIV). According to the design guide,

Choose a diode with I<sub>FAV</sub> > I<sub>AC</sub> = 1.6 I<sub>DC</sub> = 0.8 A.

Choose a diode with PIV > 1.4142 V<sub>AC</sub> = 33.94 V.

1N 4007 diodes are chosen for their rating.

$$\text{Limiting resistor for LED, } R = \frac{V - V_F}{I_F} = 300\Omega.$$

The maximum resistance is 300Ω, the suitable resistor to use circuit is 220Ω.

**Table2: Value for Rectifier and regulator From Calculation**

No.	Part Number	Description
1	T1	220 – 24V AC step-down transformer
2	D <sub>1</sub> ,D <sub>2</sub> ,D <sub>3</sub> ,D <sub>4</sub>	1N 4007 diode
3	IC <sub>1</sub>	LM7824, 24V voltage regulator
4	IC <sub>2</sub>	LM7812, 12V voltage regulator
5	IC <sub>3</sub>	LM7805, 5 V voltage regulator
6	C <sub>1(24V)</sub>	500 F / 25 V electrolytic capacitor
7	C <sub>1(12V)</sub>	1000 F / 25 V electrolytic capacitor
8	C <sub>1(5V)</sub>	2200 F / 25 V electrolytic capacitor
9	C <sub>2</sub> ,C <sub>3(24V)</sub>	0.001 F/ 50 V, 470 F/ 50V electrolytic capacitor
10	C <sub>2</sub> ,C <sub>3(12V)</sub>	0.001F/ 50 V, 470 F/ 50V electrolytic capacitor
11	C <sub>2</sub> ,C <sub>3(5V)</sub>	0.001 F/ 50 V, 470 F/ 50V electrolytic capacitor
12	R <sub>1</sub>	220 , 0.25 W resistor
13	LED	Red LED

**V. PIC MICROCONTROLLER**

Microcontrollers are widely used in today’s control system. It is a computer on chip used to control electronic device. It is a compact standalone computer optimized for control application. Like other processing devices, PIC structure composes of a CPU, RAM, EEPROM, system clock, timers, and I/O ports. Fig 8 shows the block diagram of PIC microcontroller. It contains all the functional section of a traditionally defined computer on a single integrated circuit. PIC supports build-in PWM (pulse width modulation) function for motor speed control. PWM is the most commonly technique for motor speed control.

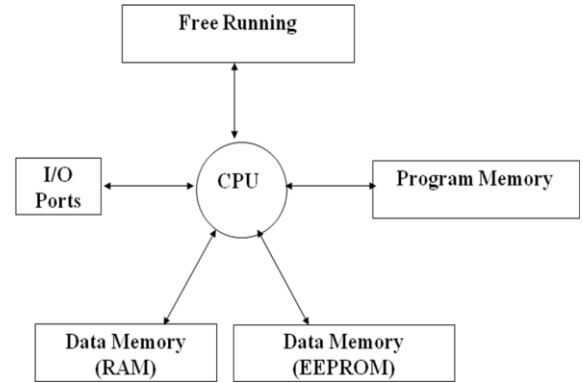

**Fig 8. Block diagram of PIC microcontroller**

It characterized by RISC architecture instead of the CISC architecture used. PIC microcontroller is to provide the system reading the signal from the sensor during the operation and sending the data . Moreover, it can also be used to control the motor driver that holds the motor to turn left, turn right and stop.

PIC microcontroller can be found as the different types of devices

- Embedded (self-contained) eight bit microcontroller
- 16 to 32 bit microcontroller
- Digital signal processor

**VI. OPERATION OF SLIDING DOOR CONTROL SYSTEM**

The basic system consists of a controller module that provide the interface with the drive motor and pulley, auxiliary battery and all sensors and second module provide the power supply of 24V dc from main 230 V ac supply. Module circuit is used as main controller for automatic door sliding system. Sensors are used to detect the person approach the sliding doors. Motors are used for rotating forward or backward direction to achieve the required positions. In this system, automatic door sliding using module circuit as main controller. Moreover, program switch can also be used in door sliding system which chooses one position of door sliding. This system is used the automatic two ways position of program switch. Module circuit has two activators (sensors). Figure 9 shows block diagram of overall system.

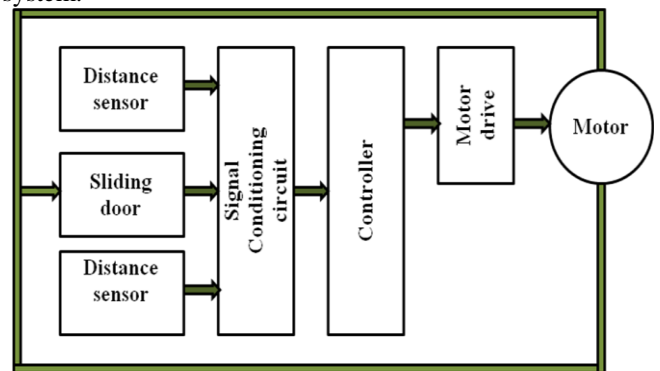

**Fig9. Proposed block diagram of automatic control system of sliding door**

## Door Operator for Automatic Sliding Door System Design

When a person reaches in front of the sensor outside or beside of the room, the operation will be started. As soon as the person reaches in front of the sensor or beside of the room, the PIC microcontroller receives the signal through the signal conditioning circuit and then the PIC controller is to drive the DC motor through the motor driver. After that the door is automatically opened. The door stops by end switch. And then the person will arrive to the room. When the person arrives in front of the second sensor inside or beside of the room, the main module circuit receives the signal and it is to drive the motor. So, the door is still open. If the persons or something are not detected in sensor area, the PIC microcontroller receives the signal and is to drive the motor. The door is automatically closed.

### VII. HARDWARE IMPLEMENTATION OF CONTROL SYSTEM

Components of Control System

1. PIC 16F887 microcontroller
2. Sensors
3. Motor driver (H-bridge L298)
4. LCD display

#### A. PIC 16F887

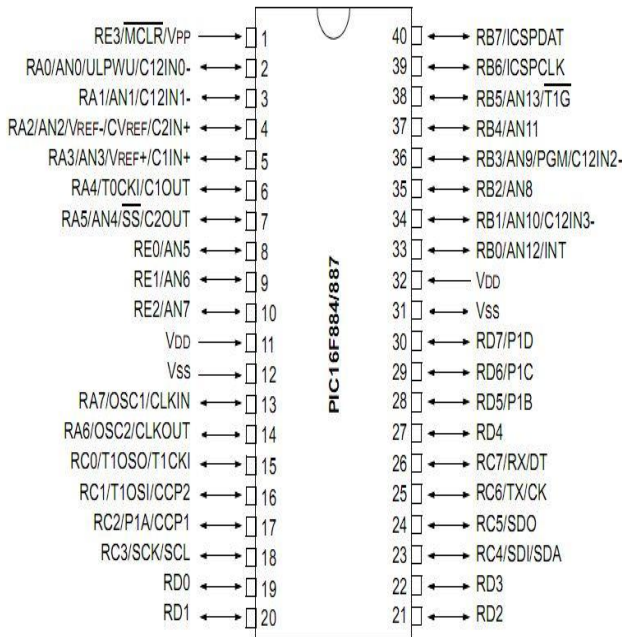

**Figure10. Pin Configuration of PIC 16F887 Micro-controller**

In this journal, PIC 16F887 microcontroller is used as receiver module to receive the data from transmitter module and to control motor driver to drive DC motors. And the path of each table for the desired workplace is stored in external EEPROM which is the output pin of this. Figure 10, describes the pin configuration of PIC 16F887 microcontroller. State of pins such as input or output analog or digital can be controlled by software coding. The demonstration model uses DC motor for door control. A lot

of control and I/O routines are needed to develop while PIC coding.

Feature of PIC 16F887 Microcontroller,

- Architecture : 8 bit
- Program Memory (Flash) : 14 kB (8 k Words)
- RAM : 368 byte
- EEPROM : 256 byte
- Pin : 40 (Pin I/O : 36)
- Max. CPU frequency : 20 MHz (5MIPS)
- Internal Oscillator : 8 MHz, 32 kHz

Peripherals of PIC 16F887 Microcontroller,

- A/D Converters : 1 (14 channels)
- Capacitive Touch Channels : 11
- Comparators : 2
- CCP Module : 1x CCP, 1x ECCP, 10-bit PWM resolutions
- Timers : 2x8-bit, 1x16-bit
- Comm. Peripherals : 1x A/E/USART , 1x MSSP (SPI/I2C)

#### B. L298 Motor Driver

Sometimes the direction of rotation needs to be changed. The direction changing is typically implemented using relays or a circuit called H-bridge. H-bridge circuit design, there are four transistors (such as BJT, FET, MOSFET, etc) are connected as a squared bridge circuit. Each edge of two transistors is connected to one pole of motor. The L298 is an integrated monolithic circuit in a 15 – lead Multi watt and PowerSO20 packages. It is a high voltage, high current dual full-bridge driver designed to accept standard TTL logic levels and drive inductive loads such as relays, solenoids, DC and stepping motors. Two enable inputs are provided to enable or disable the device independently of the input signals. The emitters of the lower transistors of each bridge are connected together and the corresponding external terminal can be used for the connection of an external sensing resistor. An additional supply input is provided so that the logic works at lower voltage. In this paper, Fig 11 shows L298 motor driver are used for running the motor forward or reversed.

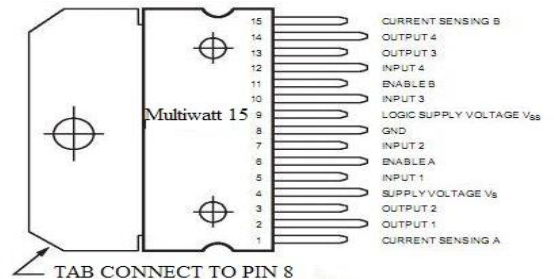

**Fig11. Pin connection of L298 motor driver.**

#### C. Liquid Crystal Display

Liquid Crystal Display (LCD) can be added a lot to the applications in terms of providing a useful interface for the user. LCDs operate by polarizing light so that a non-activated segment may reflect incident light and thus appears invisible

against its background. An activated segment does not reflect incident light and thus appears dark. In this paper, LCD in Fig 12, is used to display the door condition such as opened, closed, opening or closing.

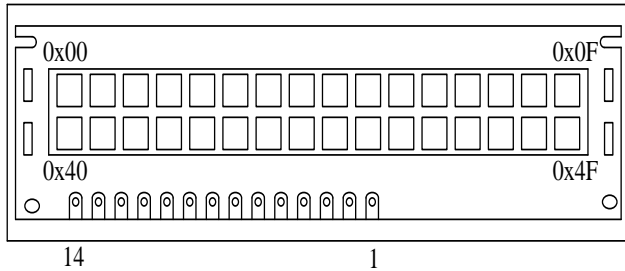

Fig12. LCD Display with 2 Lines x 16 Characters

**D. Sensors**

Sensors detected to operate the control system. Some of the sensors are higher than human senses. There are two type of sensors depending on operation; activation sensor and presence safety sensor. Activation sensors open the door when user approached it. Presence safety sensor detects obstruction and stops the door opening or closing if there is a pedestrian in the way. Automatic sliding door is used optical sensors such as photodiode, phototransistor, light dependent resistor (LDR), etc. Their characteristics with respect to light vary from one device to another as their electrical characteristics differ.

**1. Photodiode**

In Fig 13, the photodiode is a PN junction diode which is connected into a circuit in reverse bias. The photodiode can be used as a variable resistance device controlled by the light incident on it.

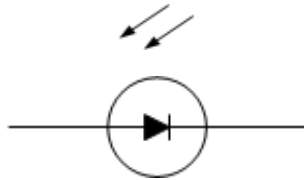

Fig13.Symbol of Photodiode

**2. Phototransistor**

The phototransistor shown in Fig 14 has a light sensitive, collector-base PN junction. When there is no incident light, there is a small thermally generated collector-to-emitter leakage current. When light strikes the collector-base PN junction, a base current is produced that is directly proportional to the light intensity.

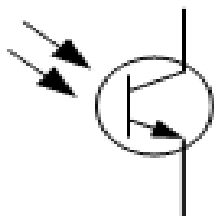

Figure14. Symbol of Phototransistor

**3. Light Dependent Resistor (LDR)**

A simple light dependent resistor (LDR) or photo resistor shown in Fig 15 is used in the circuit design. An LDR is an electronic component whose resistance decreases with increasing incident light intensity. It can also be referred to as a light dependent resistor or photoconductor. A photo resistor is made of a high resistance semiconductor.

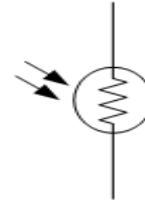

Fig15. Symbol of Light Dependent Resistor

**V. SOFTWARE IMPLEMENTATION OF THE CONTROL SYSTEM**

For software implementation, PIC Basic Pro been implemented by using Microcode Studio Complier software to program the PIC 16F887 microcontroller. The flow chart for automatic sliding door system is shown in Fig 16. In this circuit, there are four switches used as two sensors to detect the person and two edge detectors to stop the motor and two kinds of outputs are motor and display.

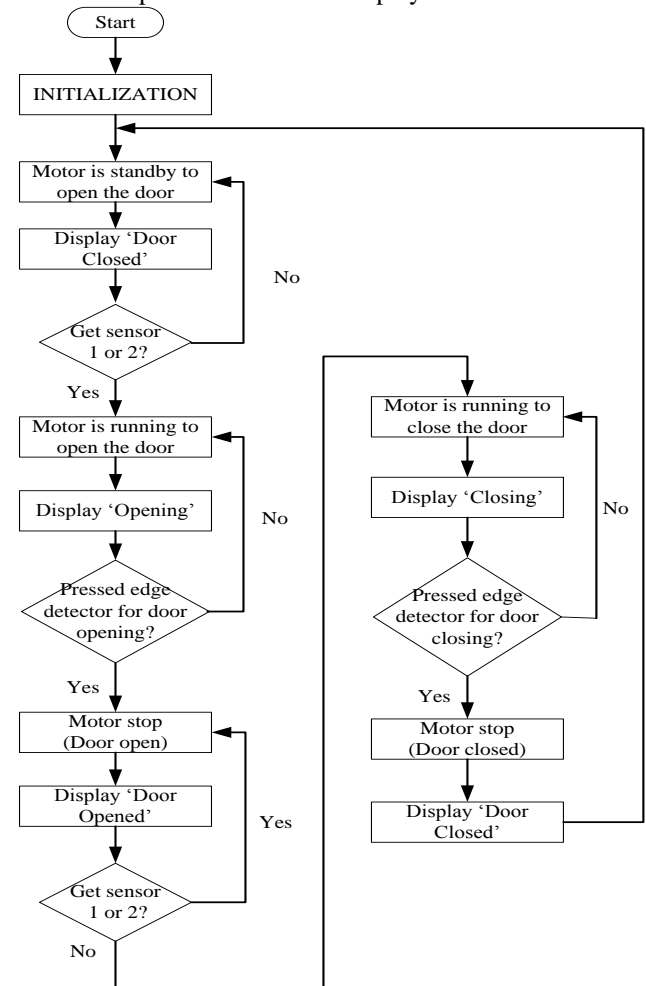

Figure 16.System Flow Chart

## Door Operator for Automatic Sliding Door System Design

When the sensors are operated, the motor running is forward direction to open the door. As if the motor running is reverse direction for closing the door. The edge detector as switches used to stop the motor running. If sensors 1 or 2 or both are operated while closing, the motor are rerunning to open the door.

### VI. SIMULATION, TEST AND RESULTS OF AUTOMATIC SLIDING DOOR SYSTEM

When the power is supplied to the circuit, the door is standby to open the door. Firstly, the program initializes the inputs, outputs and variables to open door open. The message "Door Closed" will play on LCD screen in Fig 17.



**Fig17. Displaying the door is completely closed**

When sensor 1 or sensor 2 or both are operated, the door opening until pressing the edge detector for door opening. "Door Opening" will display on LCD screen in Fig 18.



**Figure18. Displaying whether the door is opening**

When the edge detector for door opening is pressed, the motor running stop. The door still open, "Door Opened" will display on LCD screen in Fig 19.



**Fig19. Displaying the door is completely opened**

When sensor 1 and sensor 2 are not operated, the door closing until pressing the edge detector for door closing. "Door Closing" will display on LCD screen in Fig 20.

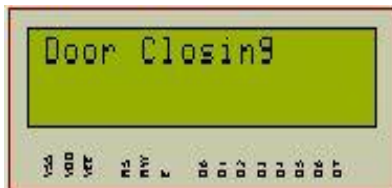

**Fig20. Displaying whether the door is closing**

When the edge detector for door closing is pressed, the motor running stop. The door closed, "Door Closed" will display on LCD screen in Fig 21.



**Fig21. Displaying the door is completely closed**

The Fig 22 shows the complete simulation diagram design for automatic sliding door access control system can test for the simulation with ISIS 7.

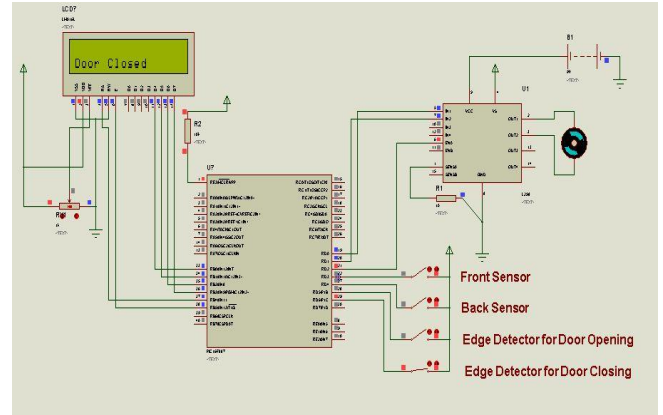

**Fig22. Simulation circuit of automatic sliding door system**

**Table 3. Components of the Main Control Circuit**

No.	Part Number	Quantity
1	R1 – R2 - R3	3
2	L298	1
3	PIC16F887	1
4	S/W	4
5	Motor	1

### VII. CONCLUSION

This journal has successfully presented a functional, low cost and low complexity microcontroller based door access control system and the design of automatic sliding door operator. The operators are found in many applications of automotive, consumer, communication, office automation, and industrial control market. In controller system, most of the digital IC portions are embedded in the PIC microcontroller. LCD display is used in this system. The circuit diagram becomes very simple and there is no complication. Opening and closing of the door may be done with various kinds of components such as solenoid valve and motor. The 24V DC motor driven by H-bridge circuit (L298) is used. An H-bridge circuit can control bidirectional for the DC motor drive. The PIC microcontroller controls the H-bridge. A pair of transistors is turned on and off to achieve counter clockwise (CCW) or clockwise (CW) rotation. Forward, reverse and stop processes of motor can be controlled by software program. Output information is shown

on LCD display screen. The implemented system uses the motor for the demonstration purpose only. And then, further consideration for feedback system, torque, and speed of motor is needed.

**VIII. REFERENCES**

- [1] William H. Yeadon, P.E, 2001, "Hand Book of Small Electric Motor", McGraw-Hill Companies, Inc.
- [2] Dr. Mittle, V.N. and Arvind Mittall. 2000, "Design of Electrical Machines", N.C. Jain.
- [3] <http://www.hortondoors.com> "Automatic Sliding Door Owner's Manual", 2000.
- [4] Smith, D. W. 2002. PIC in Practice. Gutenberg Press Ltd.
- [5] Iovine, J. 2000. PIC Microcontroller Project Book. McGraw-Hill Inc.
- [6] Myke Predko. 2000. Programming and Customizing PIC Microcontrollers. Second Edition. McGraw-Hill Inc.
- [7] Anil K. Maini, 2000. Digital Electronics: Principles, Devices and Applications John Wiley & Sons, Ltd.
- [8] Floyd, T. L. 1996. Electronic Devices. Fourth Edition. Prentice-Hall International Inc.
- [9] <http://www.microchip.com>
- [10] Dr. Mittle, V.N. and Arvind Mittall. 2000, "Design of Electrical.